

ExpressCluster is widely used by customers all over the world

Case Studies

Dream Island Department Store Co., Ltd.
Retail, China



Dream Island Department Store Co., Ltd. is a leading large scale retail store in Nanning city in Guangxi Province in China. Through the deployment of ExpressCluster, they successfully achieved high availability of critical database systems, ensured the stability of their key application systems and reduced Total Cost of Ownership (TCO) at once.

Sumitomo Electric Semiconductor Materials, Inc.
Manufacturing, United States



Sumitomo Electric Semiconductor Materials, Inc. (SESMI) is a leading Gallium Arsenide (GaAs) semiconductor product manufacturer located in Oregon. Since deploying ExpressCluster, there have been no production process interruptions due to system failures.

Port of Yokohama
Government, Japan



Located on Tokyo's southwestern edge, the port has since played an important role in the modernization of Japan's international commerce. Since the implementation of Express5800/ft series of servers and ExpressCluster, the Port of Yokohama has not experienced a single interruption of service.

ROUX ET CIE
Manufacturing, France



ROUX, specialized in the installation of electric, electronic and optical materials, has chosen ExpressCluster as the solution to protect and secure its SQL databases. This solution guarantees the performance of their production chain, allowing ROUX to offer an excellence in quality of service to its customers.

For more information, visit "http://www.nec.com/expresscluster"

The ExpressCluster mascots: Clara and Proro

- They keep important things in their pockets. (= System protection)
- They fly from tree to tree. (= Failovers)
- Their large eyes don't miss even minor dangers. (= Powerful monitoring)
- They shriek when they sense anything unusual. (= Alerts)
- They are nocturnal, and are busy even while we sleep. (= 24-hour monitoring)
- They are popular everywhere they go. (= Installation at many locations)

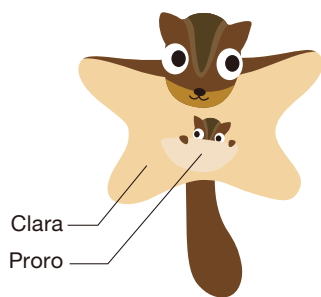

Contact Information

NEC Corporation - IT Platform Global Business Development Division

Email: info@expresscluster.jp.nec.com

For more information, visit Website: www.nec.com/expresscluster

- ExpressCluster X is a registered trademark of NEC Corporation.
- Other product names and company names in this pamphlet are trademarks or registered trademarks of their respective holders.
- Information in this pamphlet is subject to change without notice.

© 2009 NEC Corporation NEC and the NEC logo are registered trademarks of NEC Corporation.

Cat.No. E99-09090013E

High Availability Software



Ensuring Mission-Critical System Continuity



High reliability and proven technology protects your mission critical system.

The ExpressCluster series offers powerful and accurate failure monitoring features, failover features for quickly inheriting jobs to a healthy server when a failure occurs, and operation management features for determining where failures occurred at a glance.

The ExpressCluster series of middleware, which was developed in Japan, has been deployed worldwide and is a global standard for supporting business continuity.

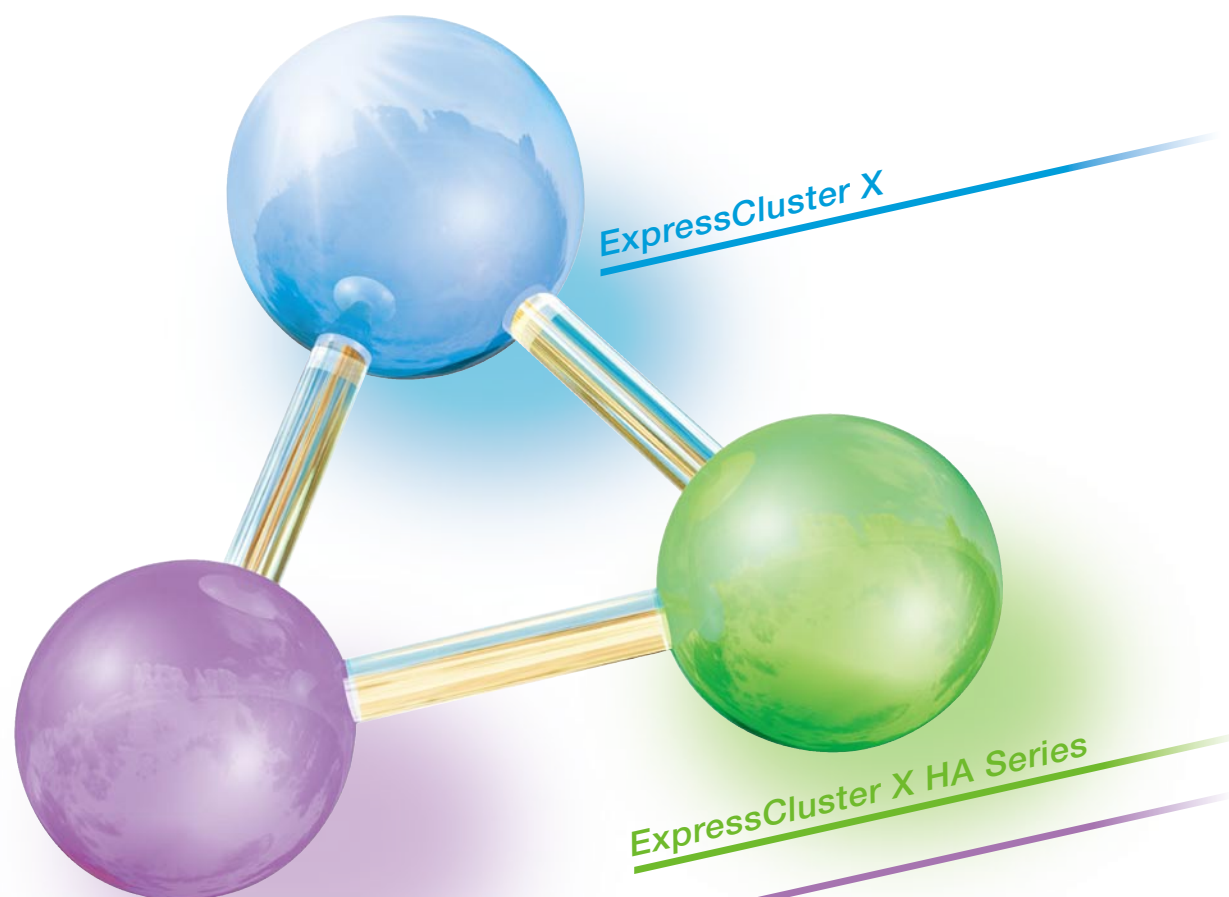

ExpressCluster X OperationHelper for Windows Server Failover Cluster



Concepts

ExpressCluster has been supporting mission-critical systems in Japan for over 10 years. We have used this wealth of experience to make ExpressCluster even more complete and to incorporate features for integrated management of different platforms and for recovering from disasters to enable business continuity. The result of these improvements is ExpressCluster X.

In addition, we have reorganized the HA series of products conventionally used to achieve high availability on UNIX platforms and OperationHelper for WSFC (Windows Server Failover Cluster), which further increases the availability of WSFC, into ExpressCluster. ExpressCluster is the start of a new age of HA systems.

- Widely deployed across the world
- Designed for Small and Large System
- Powerful and Accurate Monitoring Features
- Extremely Easy to Use
- Trusted Brand Name
- Worldwide Adoption
- Thorough Japan Quality Assurance

Cross Platform

Standardization of building and operating clusters, as well as integrated management

Regardless of your operating system (Windows, Linux, or UNIX) or cluster configuration, you can collectively manage your entire system by using one management server, and all important features can be used similarly, which makes it easy to build and manage HA systems.

Flexible support for system consolidation and modification

Even migrating from a Windows system to a Linux system can be accomplished smoothly because the look and feel of ExpressCluster is the same for both. In addition, because a significantly wider variety of system configurations are now supported, the system changes involved when, for example, companies merge or cooperate can be handled flexibly to preserve the availability of the system.

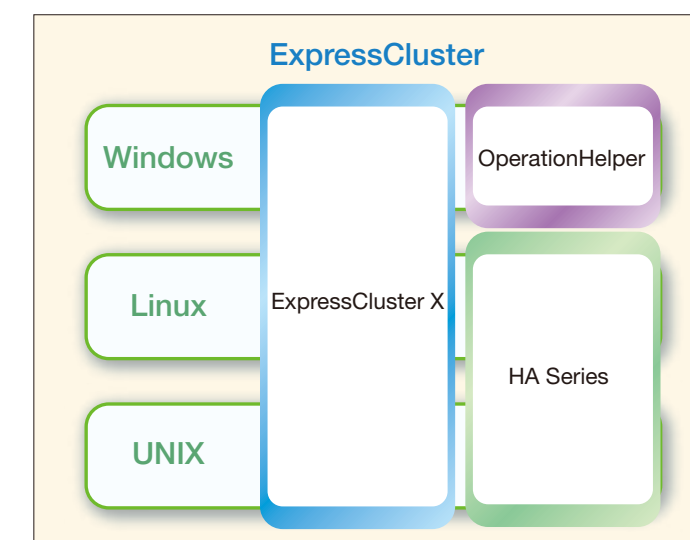

ExpressCluster X

ExpressCluster X realizes high availability by monitoring for system failures and inheriting jobs to a healthy server when a failure occurs.

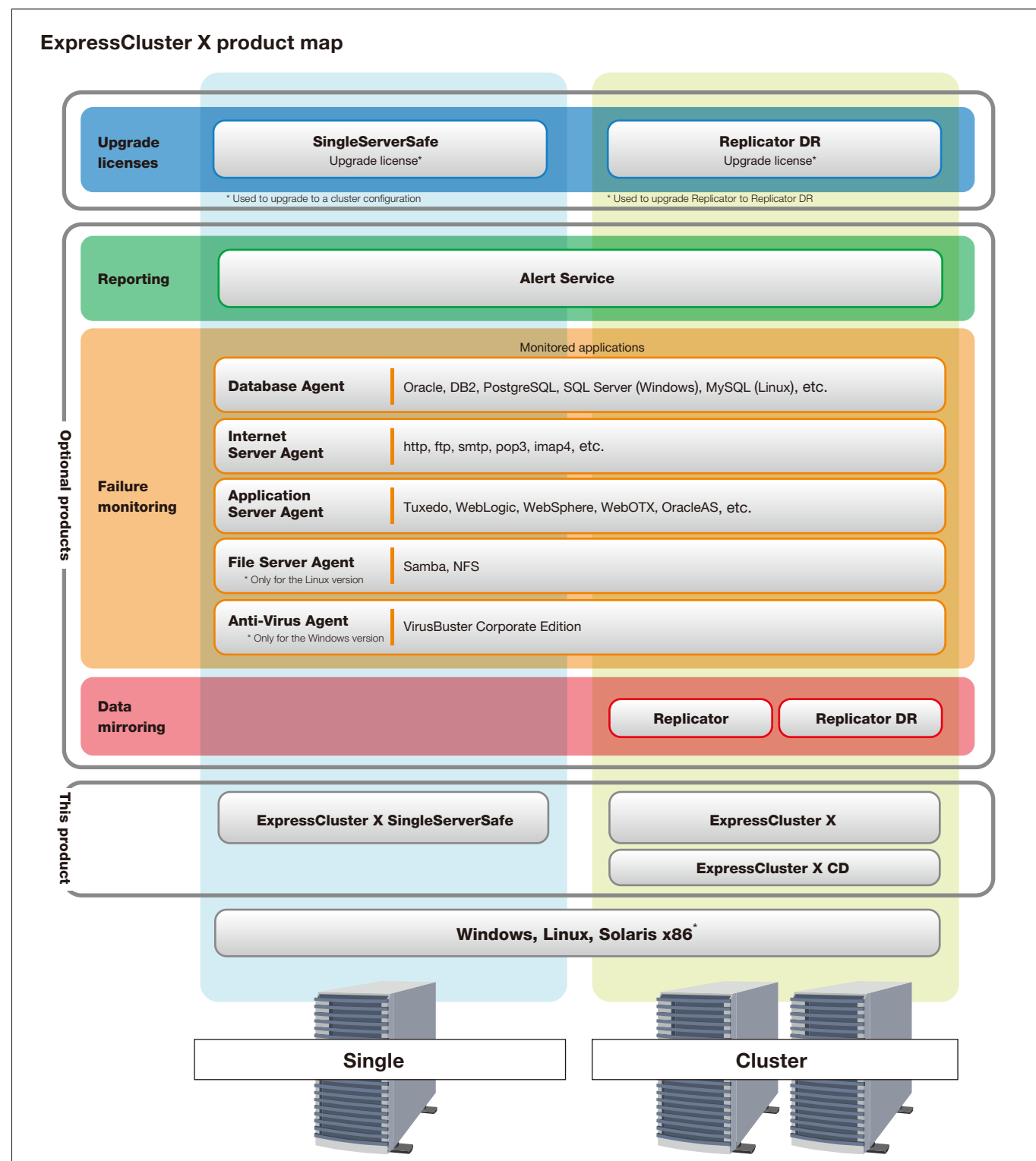

* For Solaris x86, ExpressCluster X SingleServerSafe and certain optional products are not supported. Also note that the Solaris x86 product CD differs from that used for Windows and Linux.
* The license differs for some regions.

Minimizing downtime by building a high availability (HA) cluster system

If one server in a cluster stops due to a failure or for some other reason, the applications and services running on that server are automatically inherited to a different server to minimize downtime.

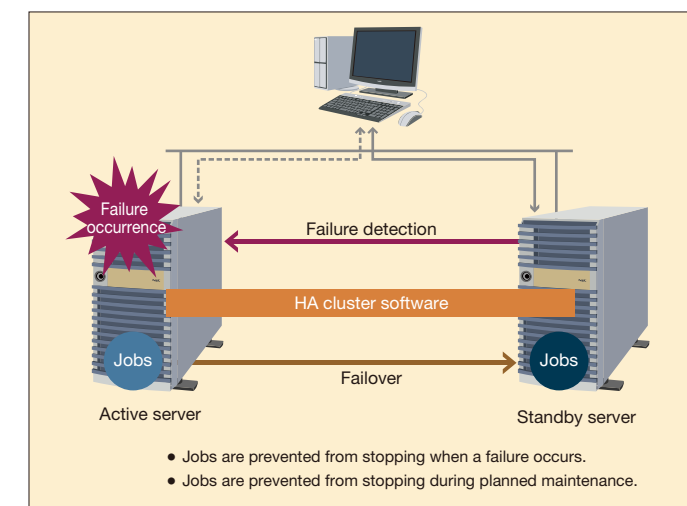

Flexible system configuration and high scalability

A significantly wider variety of system configurations are now supported such as mixed configuration of shared disk and data mirroring type. Duplication of data mirroring configuration is also available for further availability.

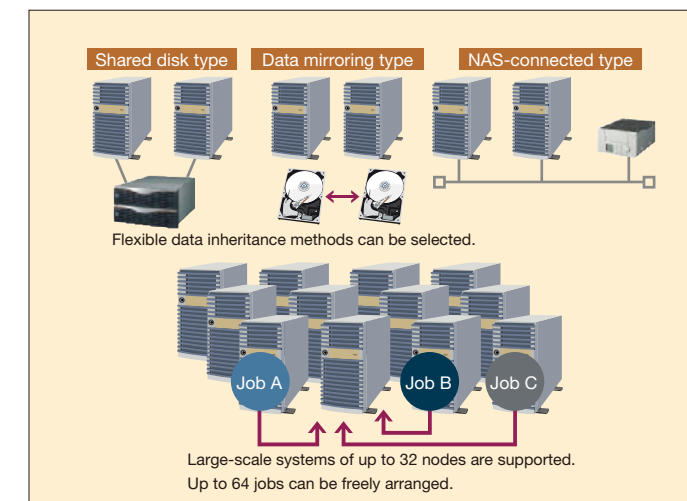

Integrated management of Windows and Linux by using single management console

Visual operations can be performed using the displayed tree views regardless of the system scale. In addition, because the views were developed based on Java, the same operations are possible regardless of the operating system.

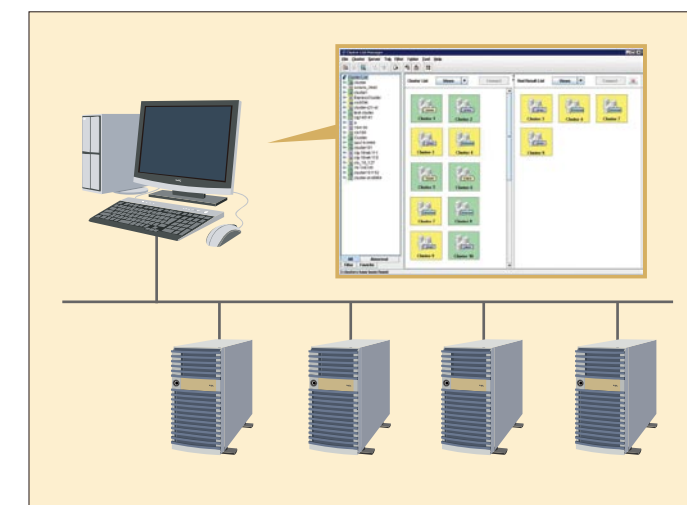

ExpressCluster X

Minimized downtime by using a variety of failure detection features

System disruption due to application bugs or human errors can be minimized by monitoring whether applications is dead or alive and by monitoring resources for failures.

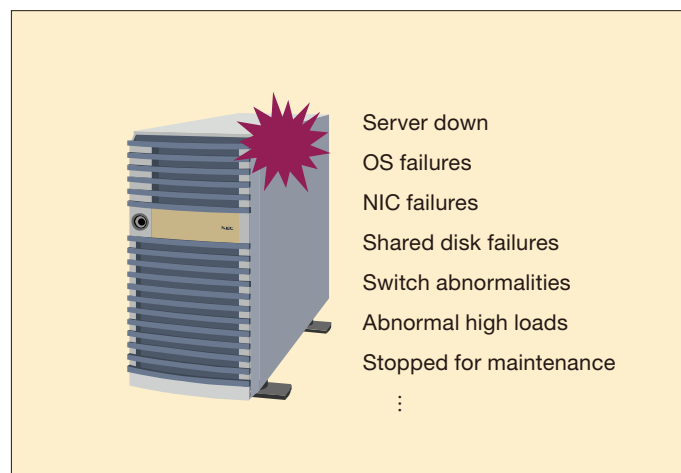

Virtual environment support

Virtualization technology is effective for server consolidation. However, if a single server is used for consolidation, a problem such as a hardware failure might cause multiple guest operating systems to go down at the same time. ExpressCluster makes it possible to cluster host operating systems and guest operating systems in virtual environments such as VMware and Hyper-V. This makes it possible to achieve high availability even in virtual environments.

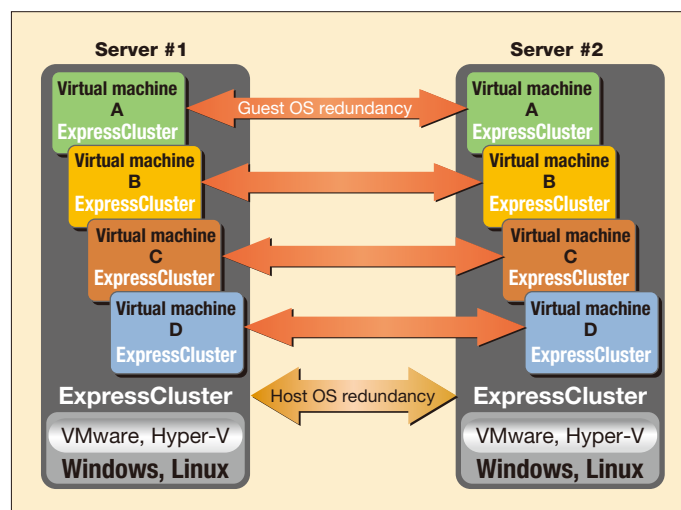

Snapshot back up by establishing a quiescent point

It is possible to establish a quiescent point for an important database so that the database consistency is preserved when making a snapshot backup of the data. This makes it possible to preserve consistency during backups while continuing jobs.

- Oracle 11g/10g (Windows/Linux)
- SQL Server 2008 (Windows)
- MySQL (Windows/Linux)
- PostgreSQL (Windows/Linux)

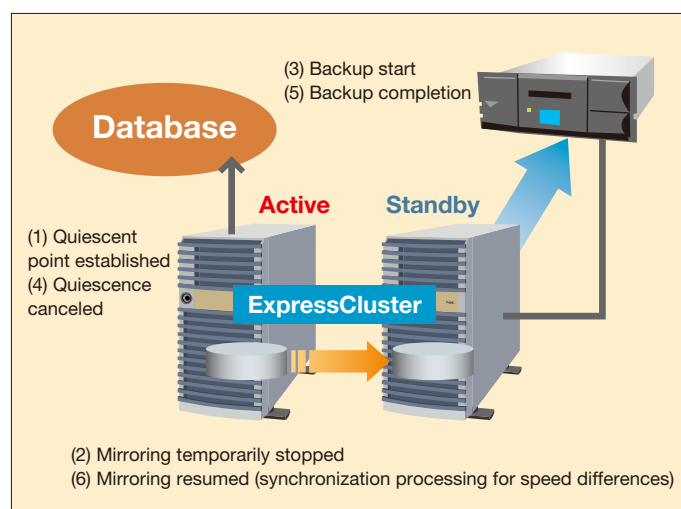

Low-cost disaster recovery clusters

Asynchronous data mirroring makes it possible to build highly reliable and low-cost disaster recovery solution even for narrow-band network or far distance configurations.

Up until now, a complicated software configuration has been required for disaster recovery clusters, but such a cluster can now be built using only cluster software.

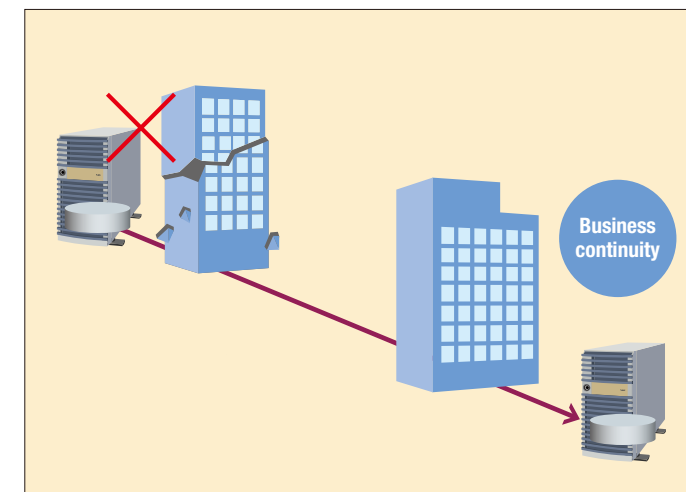

- Data mirroring features
 - Operation is possible even for narrow bandwidths.
 - Synchronous / Asynchronous data mirroring supported.
 - During data resynchronization, only data that differs is resynchronized.
- Features of clustering between different segments
 - Servers that straddle segments can be clustered.
 - Virtual IP addresses for use during routing are supported.

Shared storage mirroring

An advanced disaster recovery system can be built by combining normal cluster systems that use a shared disk at the main site and mirroring the data on the shared disk to the backup site.

When a small-scale failure occurs, a failover can be performed between clusters at the main site to continue jobs. In addition, if a large-scale failure occurs that affects the entire cluster system at the main site, the mirrored data can be used to fail over to the backup site and continue jobs.

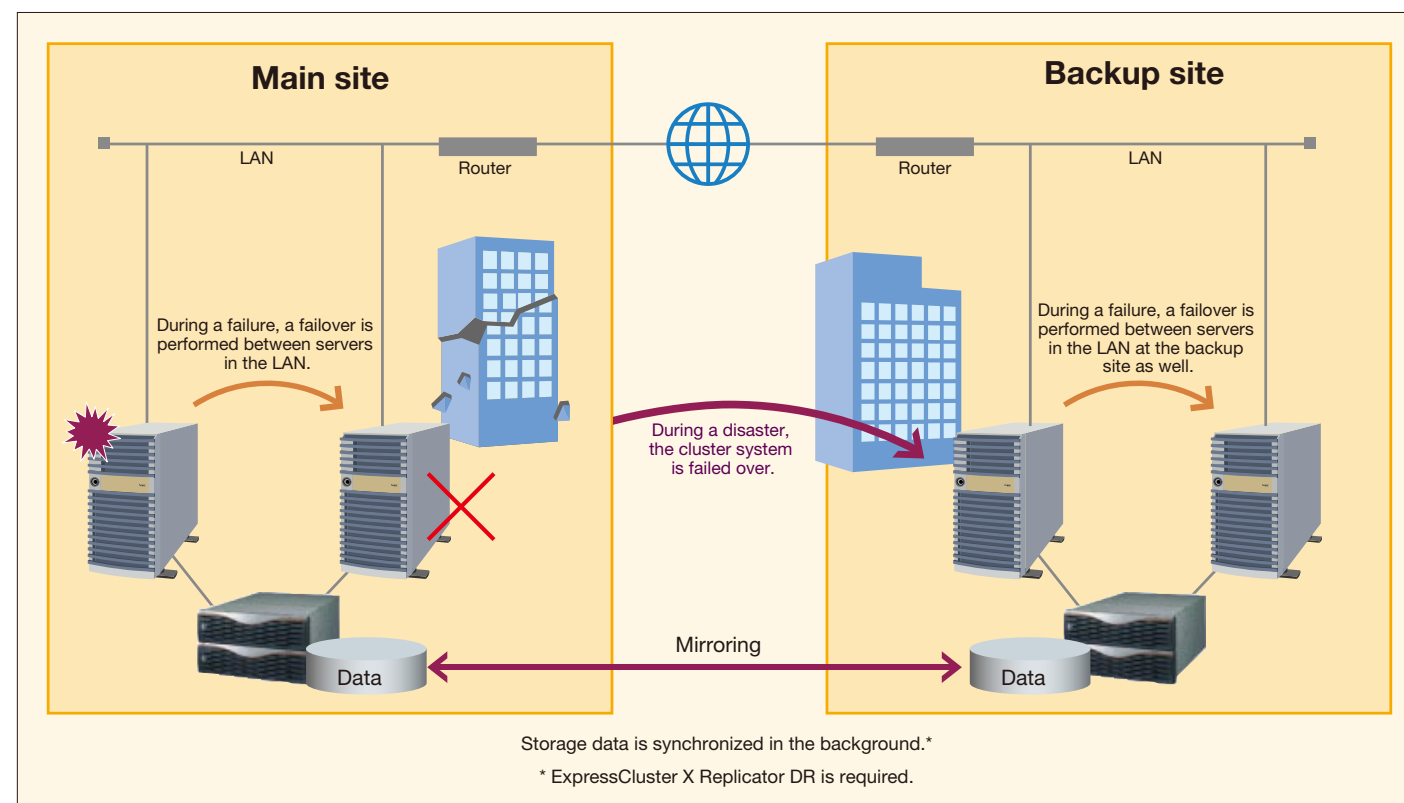

ExpressCluster X Add-On Options

ExpressCluster X Replicator

This makes it possible to build a multi-node configuration that mirrors a specific disk area of multiple servers to build a cluster without a shared disk. A high-speed mirroring recovery feature enabled by differential resynchronization is also included.

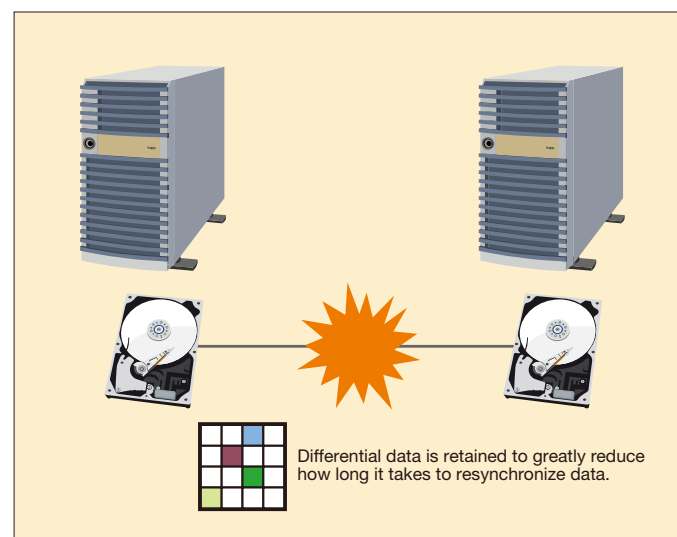

ExpressCluster X Agent

This monitors the status of various applications, including databases, HTTP, FTP, and Samba, and detects abnormalities such as hang-up and abnormal results.

* File Server Agent is only available for the Linux version, and Anti-Virus Agent is only available for the Windows version.

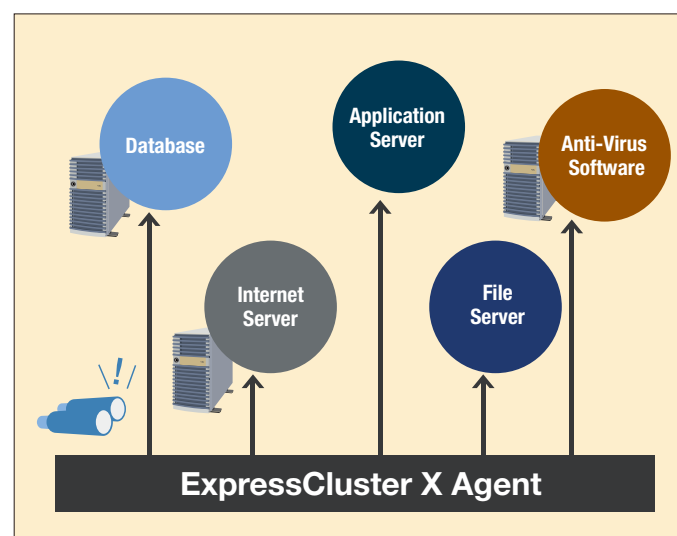

ExpressCluster X Alert Service

This makes it possible to send notification emails to the administrator when important events occur, such as server failures or failovers, just by specifying mail server information and the address to which to send the emails. Alerts are also issued through network warning lights.

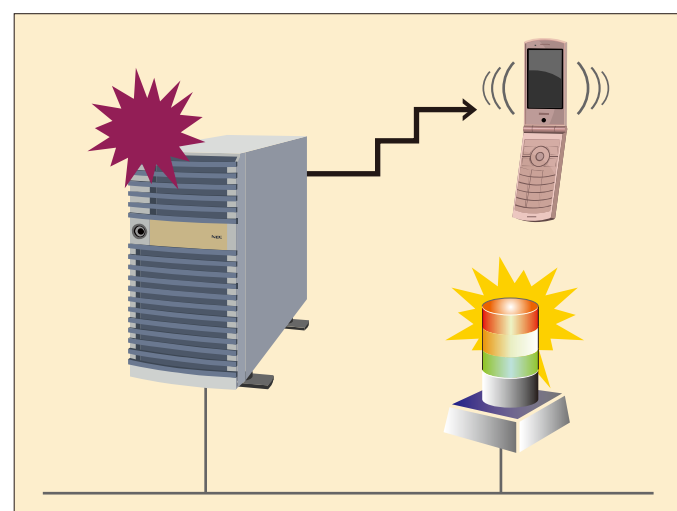

ExpressCluster X SingleServerSafe

SingleServerSafe, which is based on skills and know-how gained through ExpressCluster development, monitors for and recovers from failures.

Product overview

ExpressCluster product technology can also be effectively used for a single-server configuration

● Stop

SingleServerSafe detects when applications or services stop abnormally. When an application is detected to unexpectedly stop, it is automatically restarted to perform recovery. Custom applications can also be monitored.

● Stall

SingleServerSafe detects when software, operating systems, or hardware access hang-up. In case of hang-up, which does not leave any evidence in the syslog or failure logs, is detected, restarting is automatically performed for recovery.

● Setup

Deployment is easy because setup information is saved in a file. Because settings are created offline, switching from test to production environment is easy, as is deploying a configuration you are already using for another system.

High reliability in single-server environments

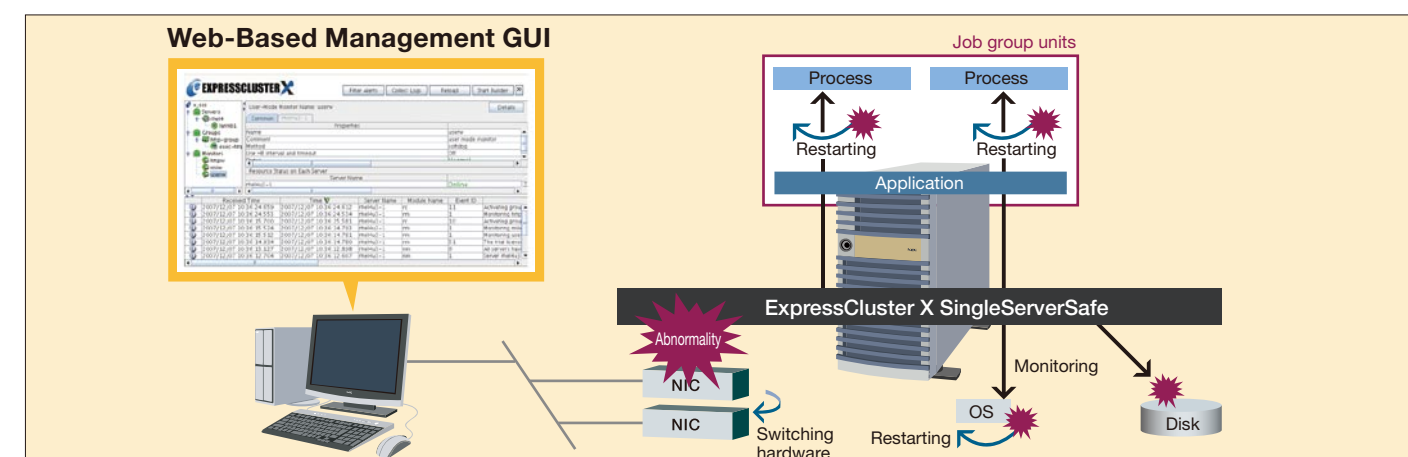

SingleServerSafe also enables integrated management of a system controlled by a load balancer possible.

If ExpressCluster X SingleServerSafe is installed on a single server or on a server controlled by a load balancer, integrated management and increased availability of the entire system from its front end to back end, can be achieved.

Integrated manager

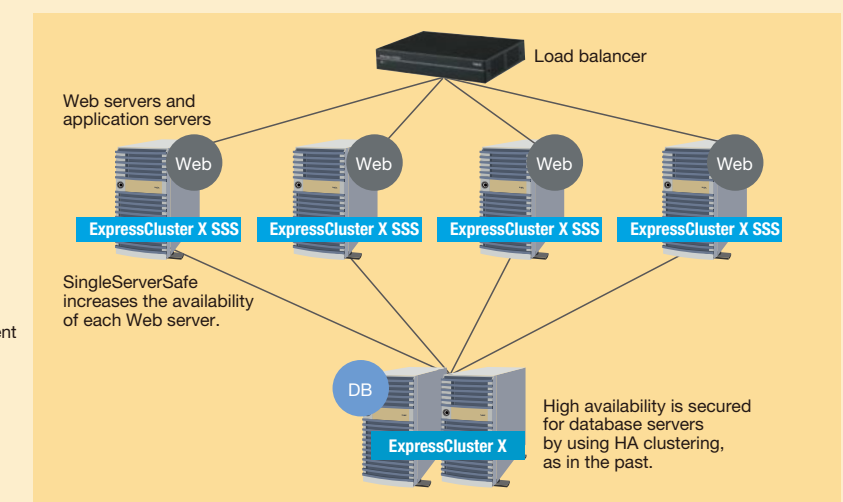
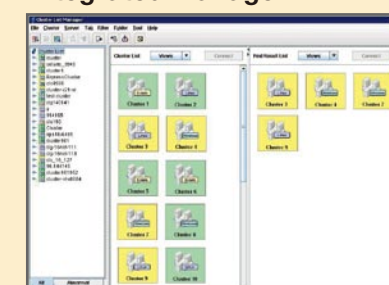

ExpressCluster X HA Series

ExpressCluster X HA Series provides high availability demanded by mission-critical systems.

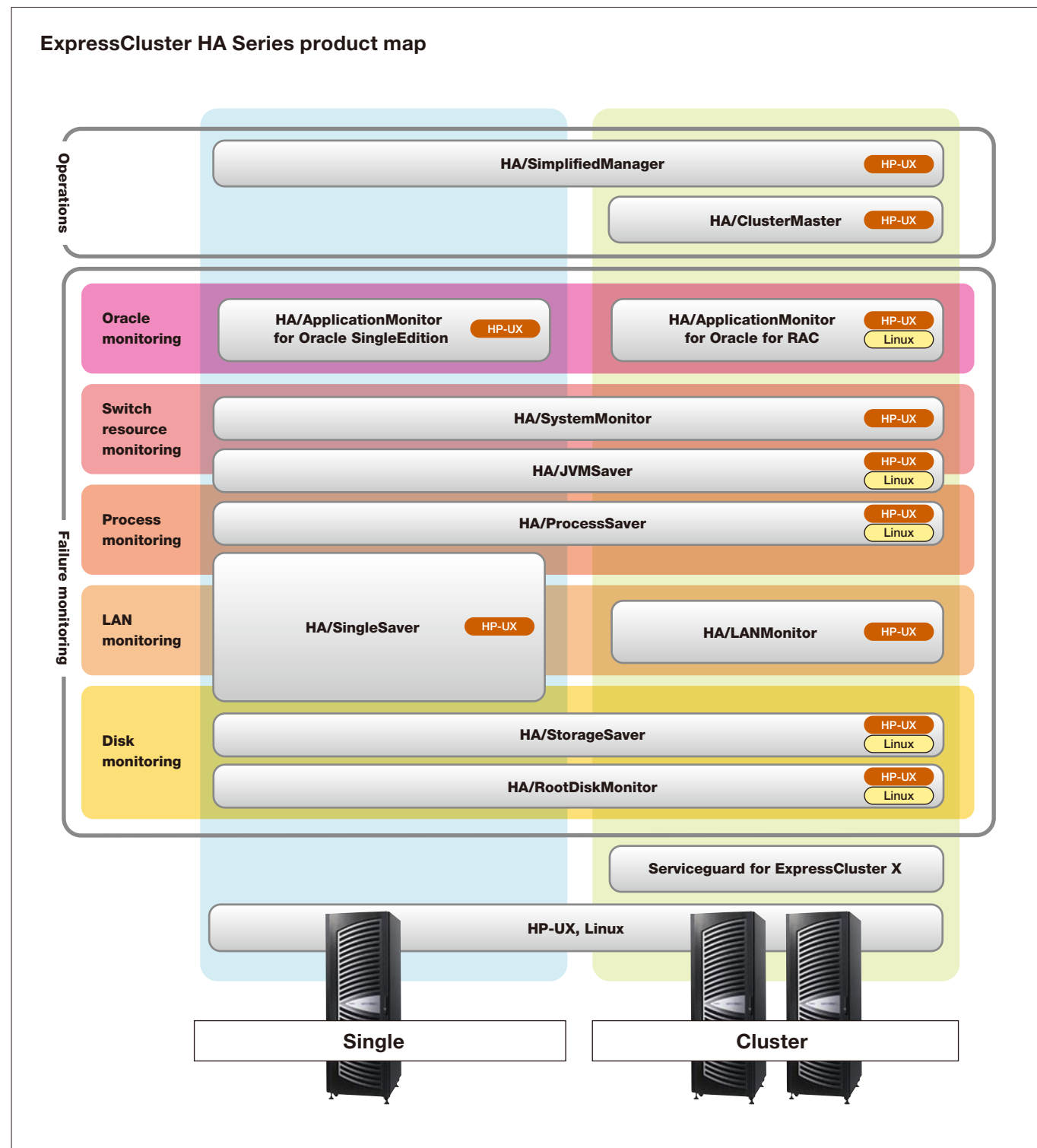

Operations

ExpressCluster X HA/SimplifiedManager

This software is used to collectively set up ExpressCluster X HA Series products running on multiple HP-UX servers. Setup and management that once had to be performed for individual servers or features can now be easily performed using GUI, and cluster systems that consist of many HP-UX servers can be efficiently managed.

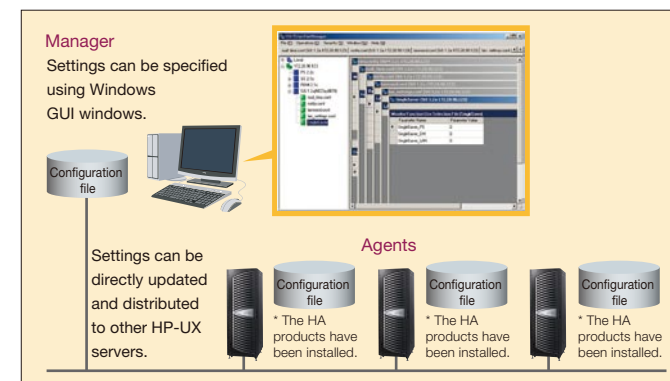

ExpressCluster X HA/ClusterMaster

This comprehensive operation software product is used to build, operate, monitor, and maintain HP-UX cluster systems by using GUI environment. The status of an HP-UX cluster can be displayed in the ExpressCluster X Integrated WebManager (GUI).

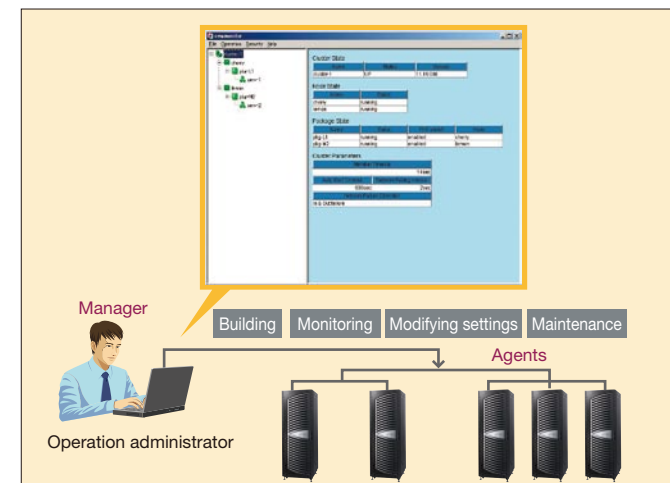

Failure monitoring

ExpressCluster X HA/SingleSaver

This software increases availability when using a single server. The software is mostly based on high availability products for existing mission-critical systems that require cluster configurations, and it includes features that are considered necessary for single servers, such as failure monitoring. The software makes business continuity possible by detecting LAN, mirror disk, and system process (daemon) failures early and then isolating failure locations, switching to working components, or restarting processes.

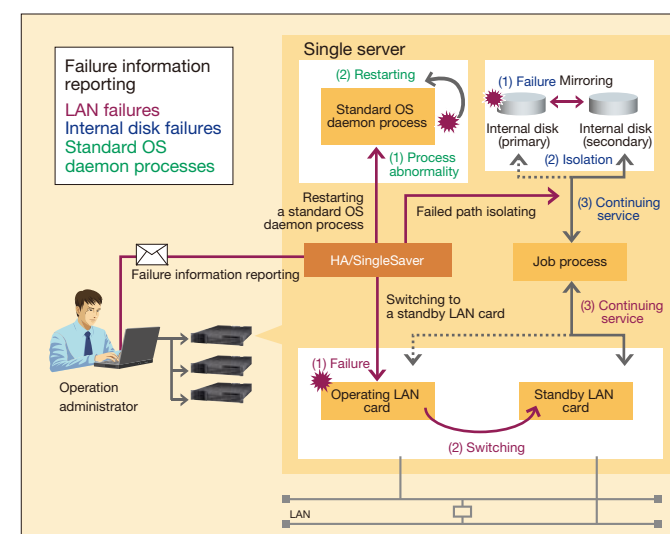

ExpressCluster X HA Series

Failure monitoring

ExpressCluster X HA/SystemMonitor

This provides features for continuously obtaining and analyzing statistics about resources used by processes to quickly detect various problems caused by processes resulting in resource depletion.

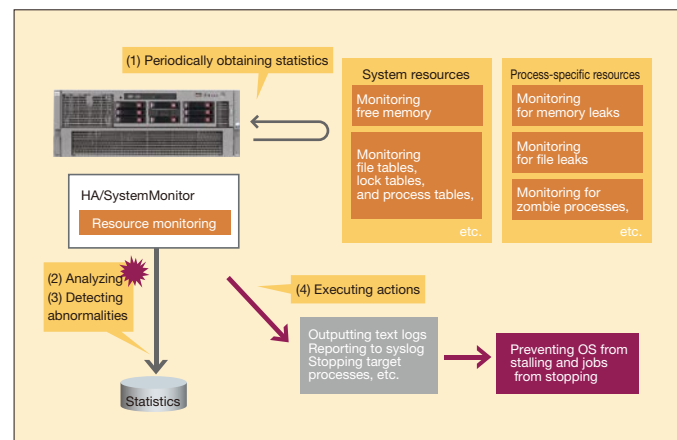

ExpressCluster X HA/JVMSaver

By monitoring operating conditions and the usage conditions of Java VM and JavaAP resources on application servers, it detects potential failures in advance and take action for them. This makes it possible to quickly resolve and recover from failures when a service goes down.

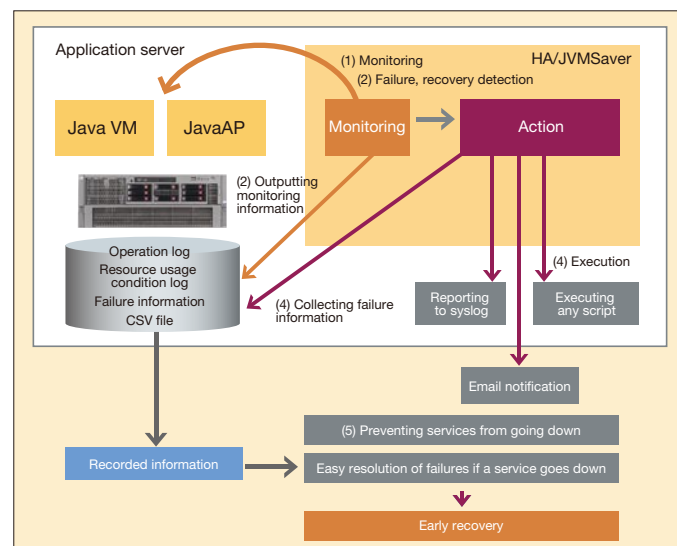

ExpressCluster X HA/ProcessSaver

This monitors the processes that make up business applications and middleware and automatically restarts terminated processes. In addition, if restarting a process fails, this software makes it possible to build a HA cluster system by, for example, linking with Clusterware to switch nodes and continue jobs.

The available optional plug-ins include HA/ProcessSaver WebEdition which provides a framework for monitoring Web server processes, HA/ProcessSaver ApsEdition which provides a framework for monitoring application servers, HA/ProcessSaver nfsEdition which provides a framework for monitoring NFS-related processes, and HA/ProcessSaver FailSafe Option which increases maintainability and availability.

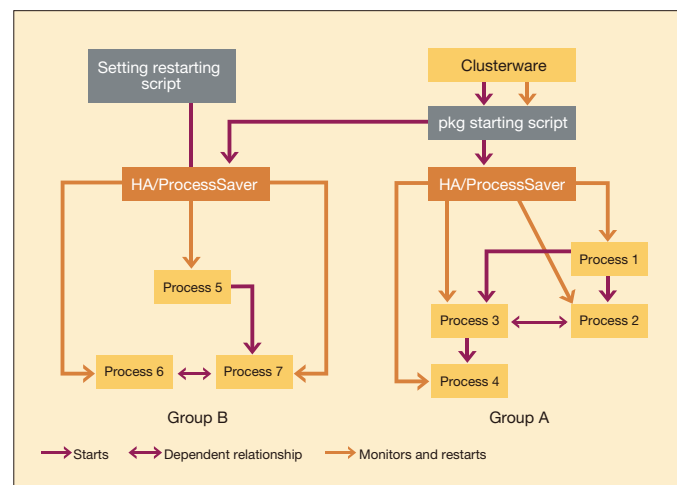

Failure monitoring

ExpressCluster X HA/ApplicationMonitor

This software monitors for failures such as Oracle stopping or not responding. By using products that support configurations ranging from single-instance configurations to RAC configurations, the availability demanded of database configurations can be achieved.

ExpressCluster X HA/ApplicationMonitor for Oracle

This monitors an Oracle database system in an active-standby configuration. This makes it possible to link to Clusterware and fail over to a standby server to continue jobs when a failure occurs.

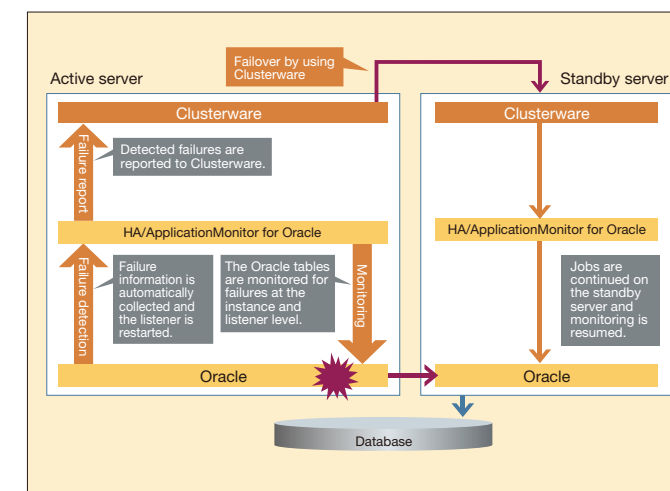

ExpressCluster X HA/ApplicationMonitor for Oracle SingleEdition

This monitors an Oracle database system in a single-instance configuration. When a failure occurs, Oracle is automatically restarted, making it possible to continue jobs. This improves the availability of databases in a single-instance configuration, which do not have a substitute server.

ExpressCluster X HA/ApplicationMonitor ClientEdition

This monitors Oracle databases on a database server from an application server to detect database access errors early. This makes it possible to quickly switch the connection destinations for business applications when such an error occurs.

ExpressCluster X HA/ApplicationMonitor for RAC

This monitors an Oracle database system in an RAC configuration. When a failure occurs, Serviceguard is linked to and the server that failed is automatically restarted, making it possible to continue jobs and maintain availability. This software supports features specific to RAC configurations, such as Oracle Clusterware monitoring.

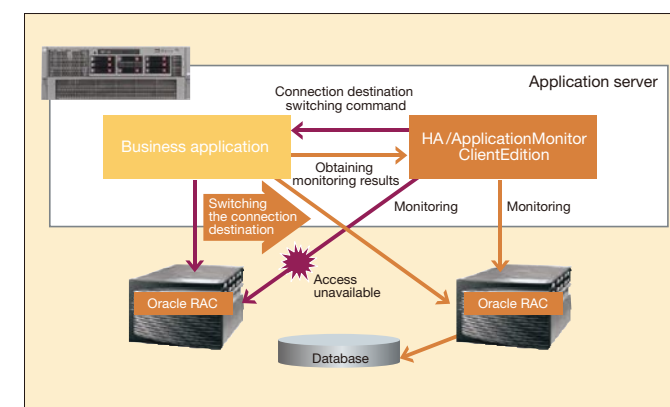

ExpressCluster X HA Series

Failure monitoring

ExpressCluster X HA/LANMonitor

This software monitors for LAN failures on a cluster server. This makes it possible to detect when links go down, when packets arrive, and to perform online maintenance.

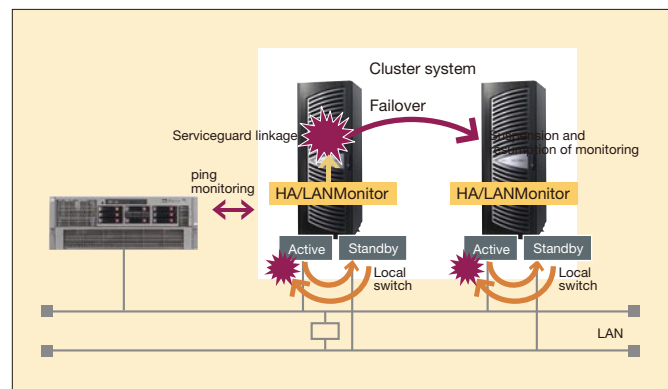

ExpressCluster X HA/StorageSaver

This software, which is used to manage operations, monitors the FC connections used to build a cluster system and the shared disk devices connected using the SCSI interface.

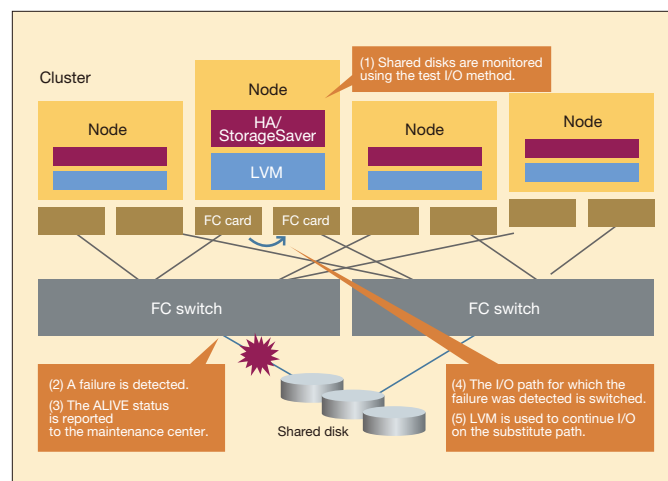

FC: Fibre Channel

ExpressCluster X HA/RootDiskMonitor

RootDiskMonitor periodically monitors the operating status of the I/O paths that make up the root disk of a server. This software improves the availability of cluster systems by generating error reports when it detects I/O path abnormalities and by linking with Clusterware to switch nodes when the root disk becomes unusable.

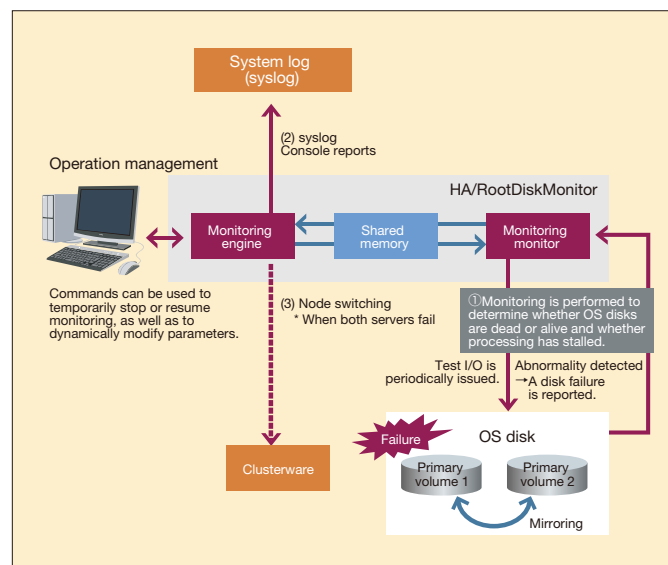

OperationHelper for Windows Server Failover Cluster

ExpressCluster improves WSFC by increasing its operational efficiency.

Increased operational efficiency

By automating the startup and shutdown of servers which must be performed manually in a standard WSFC environment, OperationHelper helps prevent problems such as startup errors due to human mistakes, data corruption, and unnecessary failovers.

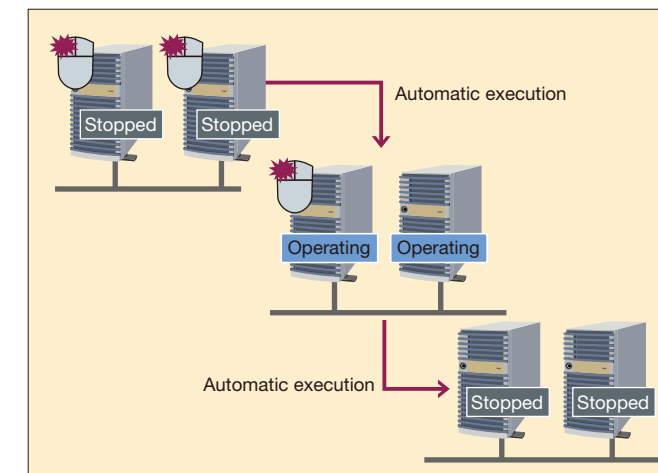

Improved availability

The group monitoring and local disk monitoring features of OperationHelper make it possible to monitor for failures of job tasks and disk resources, as well as for stalled disk I/O, and, when an abnormality is detected, failing over is automated.

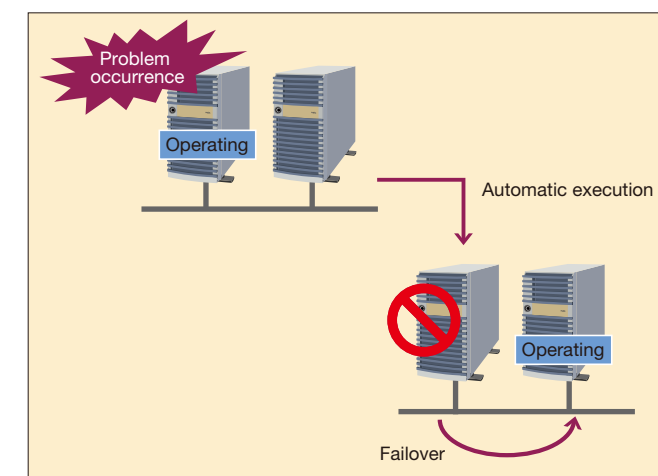

Enhanced monitoring features

Log data, such as data indicating when groups and resources are online or offline, has been added to the event log to make analysis easier. In addition, a notification email can be sent to the administrator when a failure occurs.

